

GARMIN®

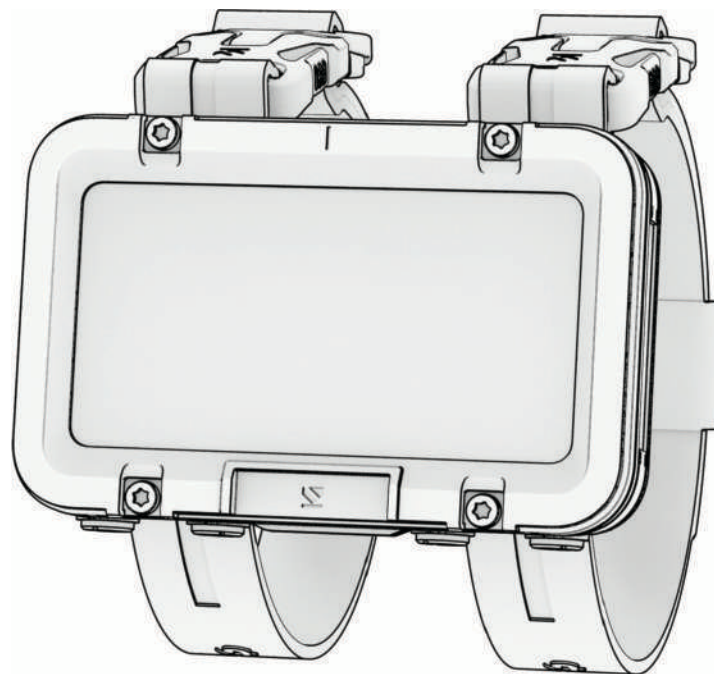

DESCENT™ X50i

Owner's Manual

 **Спорт Лайф**

Магазин спортивных часов
и пульсометров

8 (800) 333-57-82
<https://magazin-sportlife.ru>

© 2024 Garmin Ltd. or its subsidiaries

All rights reserved. Under the copyright laws, this manual may not be copied, in whole or in part, without the written consent of Garmin. Garmin reserves the right to change or improve its products and to make changes in the content of this manual without obligation to notify any person or organization of such changes or improvements. Go to www.garmin.com for current updates and supplemental information concerning the use of this product.

Garmin®, the Garmin logo, ANT®, ANT+®, and inReach® are trademarks of Garmin Ltd. or its subsidiaries, registered in the USA and other countries. Descent™, Garmin Connect™, Garmin Dive™, Garmin Explore™ and SubWave™ are trademarks of Garmin Ltd. or its subsidiaries. These trademarks may not be used without the express permission of Garmin.

The BLUETOOTH® word mark and logos are owned by the Bluetooth SIG, Inc. and any use of such marks by Garmin is under license. Wi-Fi® is a registered mark of Wi-Fi Alliance Corporation. Other trademarks and trade names are those of their respective owners.

Table of Contents

Introduction.....	1	Switching Between CC and OC Diving for a Bailout Procedure.....	18
Getting Started.....	1	Performing a Safety Stop.....	18
Device Overview.....	1	Performing a Decompression Stop..	19
Controls.....	2	Viewing Your Dynamic Depth.....	20
Using the Torch.....	2	Viewing the Map During a Dive.....	20
Marking a Dive Event.....	20	Viewing the Surface Interval App.....	21
Diving.....	2	Viewing the Dive Log App.....	22
Warning.....	0	Dive Planning.....	22
Dive Warnings.....	3	Calculating NDL Time.....	22
Caution.....	0	Calculating Your Breathing Gas.....	23
Dive Cautions.....	4	Creating a Decompression Plan.....	23
Dive Modes.....	4	Using Decompression Plans.....	23
Using the Pool Dive Mode.....	4	Altitude Diving.....	23
Dive Setup.....	5	Dive Alerts.....	24
Dive Mode Advanced Settings.....	5	Transceiver Alerts.....	26
Setting Up Your Breathing Gases.....	6	Enabling Lost Transceiver Alerts.....	26
Setting a Custom Dive Alert.....	6	Dive Product and Feature Compatibility.....	27
Setting PO2 Thresholds.....	7	Dive Terminology.....	28
Setting CCR Setpoints.....	7	Map.....	28
Customizing the Data Screens.....	8	Viewing the Map.....	28
No-Fly Time.....	8	Saving or Navigating to a Location on the Map.....	29
Dive Shortcuts.....	8	Editing a Saved Location.....	29
Air Integration.....	9	Navigating to a Saved Location.....	29
Waking the Transceiver from Low Power Mode.....	9	Map Settings.....	29
Pairing a Transceiver with a Descent Dive Computer.....	9	Advanced Map Settings.....	29
Dive Network and Air Integration Settings.....	9	Marine Map Settings.....	30
Sending Diver Messages.....	11	Routing Settings.....	30
Requesting Diver Assistance.....	11	Compass.....	30
Updating the Transceiver Software Using Your Dive Computer.....	12	Setting the Compass Heading.....	30
Dive Data Screens.....	12	Setting the North Reference.....	31
Single-Gas and Multi-Gas Data Screens.....	13	Calibrating the Compass.....	31
CCR Data Screens.....	14	Connectivity.....	31
Gauge Data Screens.....	15	Phone Connectivity Features.....	31
Going Diving.....	15	Pairing Your Phone.....	31
Navigating with the Dive Compass..	16	Garmin Dive App.....	32
Using the Gauge Dive Stopwatch.....	16	Wi-Fi Connectivity Features.....	32
Viewing Transceiver Data During a Dive.....	17	Connecting to a Wi-Fi Network.....	32
Switching Gases During a Dive.....	18	Wireless Sensors.....	32
		inReach® Remote.....	32

Settings.....	33
Display and Brightness Settings.....	33
System Settings.....	33
Satellite Settings.....	33
Resetting All Default Settings.....	34
Device Information.....	34
Charging the Device.....	34
Wearing the Device.....	35
Changing the Bands.....	35
Installing Bungee Cords.....	37
Specifications.....	38
Battery Information.....	39
Device Care.....	39
Cleaning the Device.....	39
Data Fields.....	40
Troubleshooting.....	42
Product Updates.....	42
Getting More Information.....	42
My device is in the wrong language.....	43
Is my smartphone compatible with my device?.....	43
My phone will not connect to the device.....	43
Diving.....	43
Resetting Your Tissue Load.....	43
Resetting the Surface Pressure.....	43
Acquiring Satellite Signals.....	44
Improving GPS Satellite Reception..	44

Introduction

⚠ WARNING

See the *Important Safety and Product Information* guide in the product box for product warnings and other important information.

Getting Started

When using your dive computer for the first time, you should complete these tasks to set it up and get to know the basic features.

- 1 Hold **PWR** for at least one second to turn on the dive computer ([Device Overview, page 1](#)).
- 2 Follow the on-screen instructions to complete the initial setup.
During the initial setup, you can pair your phone with your dive computer to receive notifications, sync your data, and more ([Pairing Your Phone, page 31](#)).
- 3 Charge the dive computer ([Charging the Device, page 34](#)).
- 4 Start a dive ([Going Diving, page 15](#)).

Device Overview

NOTE: There are also customizable hold functions assigned to individual buttons and button combinations during a dive ([Dive Shortcuts, page 8](#)).

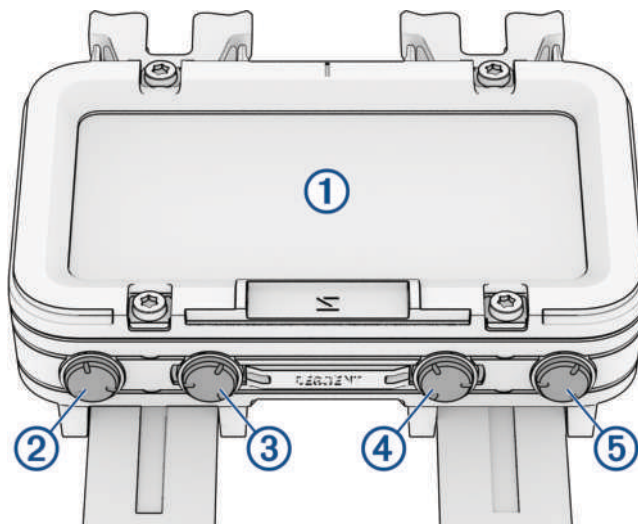

① Touchscreen

- Tap to choose an option in a menu.
- Swipe up or down to scroll through menus.
- Swipe right to return to the previous screen.

② BACK / PWR

- Press to return to the previous screen.
- Hold to turn on the dive computer.
- Hold to view the controls menu ([Controls, page 2](#)).

③ PREV

- Press to scroll through menus.

④ NEXT

- Press to scroll through menus.







⑤ ENTER / TORCH

- Press to choose an option in a menu.
- Hold to turn on the torch ([Using the Torch, page 2](#)).

Controls

The controls menu lets you quickly access device features and options.

From any screen, hold **BACK**.

Control	Description
	Select to return to the home screen.
	Select to enable touchscreen controls.
	Select to enable pool dive mode (<i>Using the Pool Dive Mode, page 4</i>).
	Select to lock the buttons and the touchscreen to prevent inadvertent presses and swipes.
	Select to open the settings menu (<i>Settings, page 33</i>).
	Select to turn off the dive computer.
Brightness	Select to adjust the brightness and display settings.
Torch	Select to turn on the torch and select the torch mode (<i>Using the Torch, page 2</i>).
Bluetooth	Select to enable Bluetooth® technology and your connection to your paired phone (<i>Pairing Your Phone, page 31</i>).
Wi-Fi	Select to enable Wi-Fi® connectivity (<i>Connecting to a Wi-Fi Network, page 32</i>).

Using the Torch

WARNING

This device has a torch (flashlight) that can be programmed to flash at various intervals. Consult your physician if you have epilepsy or are sensitive to bright or flashing lights.

You can set the torch to display in a low or bright mode, or to flash in a selected pattern.

NOTE: Using the torch can reduce battery life. You can reduce the brightness to extend the life of the battery.

1 Select an option:

- From the home screen, scroll down to the extended app list.
- From any screen, hold **BACK**.

2 Select **Torch**.

3 Select  to turn on the torch.

4 Select a torch mode.

TIP: From any screen, you can hold TORCH to turn on the torch. For the first three seconds, you can press PREV or NEXT to adjust the torch mode.

Diving

WARNING

Failure to heed the following warnings could result in an accident or medical event resulting in death or serious injury.

Dive Warnings

- The diving features of this device are for use by certified divers only. This device should not be used as a sole dive computer. Failure to input the appropriate dive-related information into the device can lead to serious personal injury or death.
- Do not exceed the maximum dive depth rating for the device (*Specifications, page 38*).
- Make sure that you fully understand the use, displays, and limitations of your device. If you have questions about this manual or the device, always resolve any discrepancies or confusion before diving with the device. Always remember that you are responsible for your own safety.
- There is always a risk of decompression illness (DCI) for any dive profile even if you follow the dive plan provided by the dive tables or a diving device. No procedure, diving device, or dive table will eliminate the possibility of DCI or oxygen toxicity. An individual's physiological make up can vary from day to day. This device cannot account for these variations. You are strongly advised to remain well within the limits provided by this device to minimize the risk of DCI. You should consult a physician regarding your fitness before diving.
- The dive computer can calculate your surface air consumption rate (SAC) and air time remaining (ATR). These calculations are an estimate and should not be relied on as the only source of information.
- Always use backup instruments, including a depth gauge, submersible pressure gauge, and timer or watch. You should have access to decompression tables when diving with this device.
- Perform pre-dive safety checks, such as checking proper device function and settings, display function, battery level, tank pressure, and bubble checks to check hoses and connections for leaks.
- If a tank pressure warning or battery warning appears on the dive computer, terminate the dive immediately and safely return to the surface. Disregarding the alarm may result in serious injury or death.
- This device should not be shared between multiple users for diving purposes. Diver profiles are user specific, and using another diver's profile can result in misleading information that could lead to injury or death.
- For safety reasons, you should never dive alone. Dive with a designated buddy, even if you have someone monitoring your dive from the surface. You should also stay with others for an extended time after a dive, because the potential onset of decompression illness (DCI) may be delayed or triggered by surface activities.
- This device is not intended for commercial or professional dive activities. It is for recreational purposes only. Commercial or professional dive activities can expose the user to extreme depths or conditions that increase the risk of DCI.
- Do not dive with a gas if you have not personally verified its contents and input the analyzed value to the device. Failure to verify tank contents and input the appropriate gas values to the device will result in incorrect dive planning information and could result in serious injury or death.
- Diving with more than one gas mixture presents a much greater risk than diving with a single gas mixture. Mistakes related to the use of multiple gas mixtures may lead to serious injury or death.
- The transceiver is not an oxygen cleaned product. Do not use the transceiver with anything greater than 40% oxygen.
- Always ensure a safe ascent. A rapid ascent increases the risk of DCI.
- Disabling the deco lockout feature on the device can result in an increased risk of DCI, which can result in personal injury or death. Disable this feature at your own risk.
- Violating a required decompression stop may result in serious injury or death. Never ascend above the displayed decompression stop depth.
- Always perform a safety stop between 3 and 5 meters (9.8 and 16.4 feet) for 3 minutes, even if no decompression stop is required.

CAUTION

Failure to heed the following cautions could result in minor or moderate injury, or property damage.

Dive Cautions

- Dive messaging requires line of sight between two compatible receivers with the latest compatible software versions. Obstructions and other environmental factors may affect receiver connectivity and may delay or prevent the sending and receiving of messages. With good connectivity, data can be successfully sent between divers in under 20 seconds. If connectivity is poor, devices will attempt to send data for up to two minutes. This is a supplemental feature that should not be relied upon as a method to receive emergency assistance and should not replace traditional dive safety tools and procedures.
 - The device range and availability of messaging and/or location tracking depends on the type of compatible devices to which this device is communicating ([Dive Product and Feature Compatibility, page 27](#)).
-

Dive Modes

The Descent™ X50i dive computer supports four dive modes. Each dive mode has four phases: dive pre-check, surface display, in-dive, and post-dive. During the pre-dive check, you can confirm the dive settings before you start diving ([Dive Setup, page 5](#)). The surface phase shows the data screens for the dive mode ([Dive Data Screens, page 12](#)). The in-dive phase shows data about the dive in progress, and other device features, such as GPS, are disabled ([Going Diving, page 15](#)). During the post-dive review, you can view a summary of the completed dive ([Viewing the Dive Log App, page 22](#)).

Single-Gas: This mode allows you to dive with a single gas blend. You can set up to 11 additional gases as backup gases.

Multi-Gas: This mode allows you to configure multiple gas blends and switch gases during your dive. You can set the oxygen content from 5–100%. This mode supports one bottom gas, and up to 11 additional gases as decompression or backup gases.

NOTE: Backup gases are not used in no-decompression limit (NDL) and time to surface (TTS) decompression calculations until you activate them during a dive.

CCR: This mode for closed-circuit rebreather (CCR) diving allows you to configure two partial pressure of oxygen (PO2) setpoints, closed-circuit (CC) diluent gases, and open-circuit (OC) decompression and backup gases.

Gauge: This mode allows you to dive with basic bottom timer features.

NOTE: After diving in gauge mode, the dive computer can only be used in gauge mode for 24 hours.

Using the Pool Dive Mode

When the device is in pool dive mode, the tissue load and decompression lockout features function normally, but dives are not saved to the dive log.

- 1 Hold **BACK** to view the controls menu.
- 2 Select .

The pool dive mode turns off automatically at midnight.

Dive Setup

You can customize the dive settings based on your needs. Not all settings are applicable for all dive modes. You can also edit the settings before you start a dive.

Select **Dive Setup**.

Gases: Sets the gas blends used in the gas dive modes ([Setting Up Your Breathing Gases, page 6](#)). You can have up to twelve gases for each gas dive mode.

Dive Network & Air Integration: Pairs Descent transceivers and configures the data screens ([Air Integration, page 9](#)).

Conservatism: Sets the level of conservatism for decompression calculations. Higher conservatism provides a shorter bottom time and a longer ascent time. The Custom option sets a custom gradient factor.

NOTE: Make sure you understand gradient factors before entering a custom level of conservatism.

Water Type: Sets the water type.

PO2: Sets the partial pressure of oxygen (PO2) thresholds, in bar, for the maximum operating depth (MOD), decompression, warnings, and critical alerts ([Setting PO2 Thresholds, page 7](#)).

Scuba Alerts: Sets custom alerts for gas dives ([Setting a Custom Dive Alert, page 6](#)).

Display Settings: Customizes the data screens for each dive mode ([Dive Data Screens, page 12](#)).

Safety Stop: Changes the safety stop duration.

Last Deco Stop: Sets the depth of the final decompression stop.

End Dive Delay: Sets the length of time before the device ends and saves a dive after surfacing.

CCR Setpoints: Sets high and low PO2 setpoints for closed-circuit rebreather (CCR) dives ([Setting CCR Setpoints, page 7](#)).

Dive Shortcuts: Assigns button shortcuts for use during dives ([Dive Shortcuts, page 8](#)).

Advanced Settings: Customizes advanced dive mode settings ([Dive Mode Advanced Settings, page 5](#)).

Dive Mode Advanced Settings

Select **Dive Setup > Advanced Settings**.

Double Tap to Scroll: Enables a double-tap on the dive computer to scroll through the dive data screens. If you notice accidental scrolling, you can use the Sensitivity option to adjust the responsiveness.

Silent Diving: Disables all tones and vibrations for alerts during dive activities.

Compass: Calibrates and set the north reference of the dive compass ([Calibrating the Compass, page 31](#)).

No-Fly Time: Sets the no-fly countdown timer mode ([No-Fly Time, page 8](#)).

Units: Sets the distance, depth, temperature, and tank pressure units of measure for diving.

Deco Lockout: Disables the decompression lockout feature. This feature prevents single-gas, multi-gas, and CCR dives for 24 hours if you violate a decompression ceiling for more than three minutes.

NOTE: You can still disable the decompression lockout feature after violating a decompression ceiling.

Setting Up Your Breathing Gases

You can enter up to twelve gases for each gas dive mode. Decompression calculations include your decompression gases, but do not include your backup gases.

1 Select **Dive Setup > Gases**.

2 Select a dive mode.

3 Select the first gas in the list.

For single-gas or multi-gas dive modes, this is the bottom gas. For the closed-circuit rebreather (CCR) dive mode, this is the diluent gas.

4 Select **Oxygen**, and enter the oxygen percentage of the gas blend.

5 Select **Helium**, and enter the helium percentage of the gas blend.

The dive computer calculates the remaining percentage as the nitrogen content.

6 Press **BACK**.

7 Select an option:

NOTE: Not all options are available for all dive modes.

- Select **Add Backup**, and enter the oxygen and helium percentage for your backup gas.
- Select **Add New**, enter the oxygen and helium percentage, and select **Mode** to set the intended use for the gas, such as decompression or backup.

NOTE: For the multi-gas dive mode, you can select **Set as Travel Gas** to set your intended gas for descending.

Setting a Custom Dive Alert

1 Select **Dive Setup > Scuba Alerts**

2 Select an option:

- Select **Add Alert** to add a new alert.
- Select the alert name to edit an existing alert.

3 If necessary, enable the alert.

4 Select an option:

NOTE: Not all options are available for all alert types.

- Select **Depth** to specify the depth that should trigger the alert.
- Select **Label** to enter a name for the alert.
- Select **Time** to specify the time interval that should trigger the alert.
- Select **Interval** to specify if the alert should trigger once or at a repeat interval.
- Select **Direction** to specify if the alert should be enabled for ascending, descending, or both.
- Select **Dive Types** to specify which dive modes should allow the alert to trigger.
- Select **Sound and Vibe** to set the alert tone, vibration, or neither.
- Select **Pop-up** to enable a pop-up notification for the alert.
- Select **Preview Alert** to see how the alert appears and sounds during a dive.

Setting PO2 Thresholds

You can configure the partial pressure of oxygen (PO2) alert message thresholds, in bar.

- 1 Select **Dive Setup > PO2**.
- 2 Select an option:
 - Select **MOD/Deco PO2** to set the maximum operating depth (MOD) and decompression PO2 threshold for your planned bottom gas before you should begin your ascent and switch to the decompression gas with the highest percentage of oxygen.
NOTE: The dive computer does not switch gases for you automatically. You must select the gas.
 - Select **PO2 Warning** to set the threshold for the highest oxygen concentration level that you are comfortable reaching.
 - Select **PO2 Critical** to set the threshold for the maximum oxygen concentration level that you should reach.
- 3 Enter a value.

If you reach the PO2 Critical threshold value during a dive, the dive computer displays an alert message ([Dive Alerts, page 24](#)).

Setting CCR Setpoints

You can configure the high and low partial pressure of oxygen (PO2) setpoints for closed-circuit rebreather (CCR) dives.

- 1 Select **Dive Setup > CCR Setpoints**.
- 2 Select an option:
 - To configure the lower PO2 setpoint, select **Low Setpoint**.
 - To configure the upper PO2 setpoint, select **High Setpoint**.
- 3 Select **Mode**.
- 4 Select an option:
 - To automatically change the setpoint based on your current depth, select **Auto**.
NOTE: For example, if you descend through the high setpoint depth or ascend through the low setpoint depth, the PO2 threshold switches to the high or low setpoint, respectively. Automatic setpoint depths must be at least 6.1 m (20 ft.) apart.
 - To manually change setpoints during a dive, select **Manual**.
NOTE: If you manually change setpoints within 1.8 m (6 ft.) of an automatic switch depth, then automatic setpoint switching is disabled until you are more than 1.8 m (6 ft.) above or below the automatic switch depth. This prevents unintended setpoint switching.
- 5 Select **PO2**, and enter a value.
- 6 If necessary, select **Depth**, and enter a depth value for the automatic setpoint change.

Customizing the Data Screens

You can show, hide, and change the layout and content of data screens for each dive mode.

- 1 Select **Dive Setup > Display Settings**.
- 2 Select a dive mode to customize.
- 3 Select **Data Screens**.
- 4 Select a data screen to customize.
- 5 Select .
- 6 Select an option:
 - Select **Layout** to adjust the number of data fields on the data screen.
 - Select **Data Fields**, and select a field to change the data that appears in the field.
TIP: For a list of all the available data fields, go to [Data Fields, page 40](#).
 - Select **Reorder** to change the location of the data screen in the loop.
 - Select **Remove** to remove the data screen from the loop.**NOTE:** Not all options are available for each data screen.
- 7 If necessary, select **Add New** to add a data screen to the loop.
You can add a custom data screen, or select one of the predefined data screens.

No-Fly Time

After a dive, you may need to wait several hours before it is safe to fly on an airplane. To indicate your remaining no-fly time, ✈ appears on the home screen. You can view more details in the surface interval app ([Viewing the Surface Interval App, page 21](#)).

Select **Dive Setup > Advanced Settings > No-Fly Time**.

No-Fly Time Mode	Dive Type	No-Fly Time
Standard or 24 Hours	Dive duration of 3 minutes or less or depth of 5 m (15 ft.) or less.	0 hours
Standard	Non-decompression dive more than 48 hours since the previous dive.	12 hours
Standard	Multiple non-decompression dives within 48 hours.	18 hours
Standard	Dive with a completed decompression stop.	24 hours
24 Hours	Non-gauge dive that did not violate the decompression plan.	24 hours
Standard or 24 Hours	Gauge dive or a dive that violated the decompression plan.	48 hours

Dive Shortcuts

Hold functions are assigned to individual buttons and button combinations during a dive. You can customize the hold functions for most of the shortcuts ([Dive Setup, page 5](#)).

TORCH: Turns the torch on or off ([Using the Torch, page 2](#)).

BACK: Returns to the home screen.

PREV: Displays the divers in your network.

NEXT: Selects a diver message to send ([Sending Diver Messages, page 11](#)).

NEXT + ENTER: Sets the compass heading ([Navigating with the Dive Compass, page 16](#)).

BACK + PREV: Opens the breathing gas setup menu ([Setting Up Your Breathing Gases, page 6](#)).

Air Integration

The Descent X50i dive computer can be used with a paired Descent transceiver to view your tank pressure, estimated air time remaining, and estimated gas consumption. When you pair your dive computer with another diver's transceiver, you can view their depth, distance, and tank pressure. Compatible devices can send and/or receive diver messages within your dive network ([Dive Product and Feature Compatibility, page 27](#)). For more information about the Descent transceiver, see the owner's manual for your device.

Waking the Transceiver from Low Power Mode

Out of the box, the transceiver is in low power mode. You must wake the transceiver from low power mode to pair and connect to it.

Select an option:

- Install the transceiver on the first-stage regulator, and gradually open the tank valve to pressurize the regulator.

NOTE: This option is not available for Bluetooth pairing. Bluetooth technology is disabled when the transceiver is pressurized.

- Twist the battery cover counter-clockwise 270 degrees, wait 30 seconds, then twist the battery cover clockwise until it is secure.

NOTE: The transceiver remains awake for two minutes before returning to low power mode.

The transceiver plays a tone when it wakes from low power mode and is ready to connect to your Descent dive computer ([Pairing a Transceiver with a Descent Dive Computer, page 9](#)) or phone.

Pairing a Transceiver with a Descent Dive Computer

Before you use the transceiver for the first time, you must pair it with a compatible Descent dive computer using ANT[®] technology.

1 Wake the transceiver from low power mode ([Waking the Transceiver from Low Power Mode, page 9](#)).

2 On your Descent dive computer, select **Dive Setup > Dive Network & Air Integration > Transmitters**.

3 Select an option:

- To add your own transceiver, select **Add Your Tank**, select your transceiver from the list, enter your transceiver ID, and select an option for gas consumption calculations.

NOTE: The transceiver ID is printed on the housing.

- To add another diver's transceiver, select **Add Other Divers**, select at least one transceiver from the list, and select **Add**.

When the pairing process is complete, the transceiver begins sending data, and it is ready to use on a dive. The next time the transceiver and dive computer are turned on and within wireless range, they connect automatically when you start a dive.

If you are diving with a group, you can pair up to 8 transceivers with the dive computer.

Dive Network and Air Integration Settings

You can customize the settings for paired transceivers prior to a dive.

NOTE: Some settings are available only for your own transceiver or another diver's transceiver.

Select **Dive Setup > Dive Network & Air Integration**.

Transmitters: Customizes the settings for paired transceivers. ([Transceiver Settings, page 10](#))

SubWave Features: Enables SubWave™ features, such as messaging.

NOTE: SubWave features are only available when you are paired to a Descent T2 transceiver ([Dive Product and Feature Compatibility, page 27](#)).

Quick Access Messages: Customizes which preset messages are available to send to divers in your dive network ([Sending Diver Messages, page 11](#)).

Gas Consumption Rate: Changes the gas consumption rate for your transceiver ([Selecting the Gas Consumption Rate Metric, page 10](#)).

Connection Alert: Enables or disables alerts when paired transceivers connect and disconnect.

Transceiver Settings

You can customize the settings for paired transceivers prior to a dive.

Select **Dive Setup > Dive Network & Air Integration > Transmitters**, and select a transceiver.

NOTE: Some settings are available only for your own transceiver or another diver's transceiver.

Status: Enables a connection to the transceiver, and shows the current connection status. Connected transceivers show data during a dive and can send or receive messages.

Placement: Sets the transceiver location as either your own tank or that of another diver.

Public Tank Name: Associates a name with your transceiver, which will be visible to your dive network the next time you connect to your transceiver.

NOTE: If you customize this name, another option appears in the list to clear the name.

SubWave Status: Displays what SubWave features are currently available based on the devices present and their current software version. This helps you determine if a software update is needed.

Nickname: Associates a nickname with another diver's transceiver, which will be visible on your dive data screens. This setting does not change the name that appears for other divers.

NOTE: If you customize this name, another option appears in the list to clear the name.

Identify: Plays a tone on the selected paired transceiver. This helps you to identify the transceiver without needing to look at the transceiver ID printed on the transceiver housing.

Working Pressure: Sets how much pressure the tank has when full. This value is used to determine the upper end of the pressure gauge, and to calculate respiratory minute volume (RMV) for tanks using psi units.

Reserve Pressure: Sets the threshold values for reserve pressure and critical pressure alerts to appear on the dive computer.

Volume: Sets the air volume of the tank. You can use the Reset Volume option if you move the transceiver to a different size tank.

NOTE: This value is required to calculate volumetric surface air consumption (SAC) and respiratory minute volume (RMV) ([Selecting the Gas Consumption Rate Metric, page 10](#)).

SAC/RMV/ATR: Enables calculations for volumetric surface air consumption (SAC), respiratory minute volume (RMV), and air time remaining (ATR) estimates for your transceiver.

Set Transmit Power: Adjusts the power setting if your transceiver is losing connection with the paired dive computer underwater.

About: Displays the transceiver ID, software version, and battery status.

Remove: Removes a paired transceiver.

Software Update: If an update is available, updates the transceiver software using your dive computer ([Updating the Transceiver Software Using Your Dive Computer, page 12](#)).

Selecting the Gas Consumption Rate Metric

1 Select **Dive Setup > Dive Network & Air Integration > Gas Consumption Rate**.

2 Select an option.

NOTE: The dive computer can estimate volumetric surface air consumption (SAC) or respiratory minute volume (RMV) only if the air volume of the tank is entered in the dive computer ([Transceiver Settings, page 10](#)). The dive computer can estimate pressure-based surface air consumption (PSAC) with or without the air volume of the tank.

Selecting Transceivers to View During a Dive

You can view three paired transceivers at-a-glance on the transceiver data screen. You can customize which paired transceivers appear on the screen. By default, the first three transceivers that you pair appear ([Viewing Transceiver Data During a Dive, page 17](#)).

1 Select **Dive Setup > Dive Network & Air Integration > Transmitters > Pinned Tanks**.

2 Select up to three transceivers.

Sending Diver Messages

CAUTION

Dive messaging requires line of sight between two compatible receivers with the latest compatible software versions. Obstructions and other environmental factors may affect receiver connectivity and may delay or prevent the sending and receiving of messages. With good connectivity, data can be successfully sent between divers in under 20 seconds. If connectivity is poor, devices will attempt to send data for up to two minutes. This is a supplemental feature that should not be relied upon as a method to receive emergency assistance and should not replace traditional dive safety tools and procedures.

When paired to your compatible Descent transceiver, you can send preset messages to other members of your dive network up to 30 m (98 ft.) away.

- 1 During a dive, press **ENTER**.
- 2 Select **Divers**.
- 3 Select an option:
 - To view all of the recent messages from your diver network, select **All Messages**.
 - To view the recent messages from one diver in your network, select the diver.
- 4 Press **NEXT**.
TIP: You can press PREV to scroll through your recent messages.
- 5 If necessary, select a recipient.
- 6 Select a message.

Requesting Diver Assistance

WARNING

Assistance is a supplemental feature and should not be relied upon as a primary method to obtain emergency assistance. Your device cannot contact emergency services on your behalf.

If you are in distress during a dive, you can send a message requesting help to the other members of your dive network.

- 1 Hold **BACK** until you are prompted to release it for assistance.
NOTE: If you do not release BACK soon after the prompt, the dive computer will restart.
After a brief countdown, a request for help will be sent every two minutes. The flashlight on your dive computer will also flash in a distress pattern.
- 2 If necessary, hold **BACK** to cancel the request for help.
A message indicating you are okay is sent to the other members of your dive network.

Updating the Transceiver Software Using Your Dive Computer

Before you can update the software, you must pair your Descent transceiver with a Descent X50i dive computer.

1 Select an option to sync your dive computer:

- Sync your dive computer with the Garmin Dive™ app.
- Connect the dive computer to your computer using the USB cable, and sync with the Garmin Express™ application.

The Garmin Dive app and Garmin Express application automatically look for software updates. When you sync with the Garmin Dive app, you will be prompted to apply the update at a later time. When you sync with the Garmin Express application, the update is applied immediately to your dive computer.

2 Wake the transceiver from low power mode ([Waking the Transceiver from Low Power Mode, page 9](#)).

3 On the paired Descent dive computer, select **Dive Setup** > **Dive Network & Air Integration** > **Transmitters**, and select your transceiver.

4 Wait for the transceiver to connect to your dive computer.

Connected appears on the dive computer screen.

5 Select **Software Update**, press **ENTER**, and select **Install Now**.

NOTE: The Software Update option may take up to a minute to appear while the dive computer determines the transceiver's software version and battery status. If the battery status is low or critically low, you must replace the battery before you can install the update.

6 Keep the dive computer near the transceiver until the software update is complete.

Dive Data Screens

You can press **NEXT** or double-tap the device to scroll through the data screens.

In the activity settings, you can reorder the default data screens, add a dive stopwatch, and add custom data screens ([Customizing the Data Screens, page 8](#)). You can customize the data fields on some of the data screens.

Single-Gas and Multi-Gas Data Screens

The primary data screen for single-gas and multi-gas dive modes displays the main dive data, including your breathing gas, rate of ascent or descent, maximum depth, time to surface (TTS), the time of day, and the current temperature. You can press **NEXT** to view the dive compass (*Navigating with the Dive Compass, page 16*).

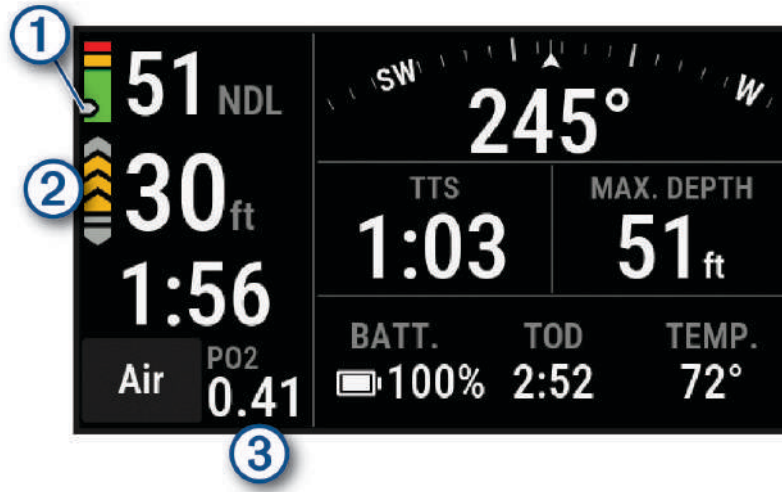

①	<p>Your nitrogen (N₂) and helium (He) tissue load level.</p> <ul style="list-style-type: none"> Green: 0 to 79% tissue load. Yellow: 80 to 99% tissue load. Red: 100% or greater tissue load.
②	<p>Your rate of ascent.</p> <ul style="list-style-type: none"> Green: Good. Ascent is less than 7.9 m (26 ft.) per minute. Yellow: Moderately high. Ascent is between 7.9 and 10.1 m (26 and 33 ft.) per minute. Red: Too high. Ascent is greater than 10.1 m (33 ft.) per minute.
③	<p>Your partial pressure of oxygen (PO₂) level.</p> <p>NOTE: In the single-gas dive mode, this field does not appear if you are using air for your breathing gas.</p>

CCR Data Screens

The primary data screen for the CCR dive mode displays the main dive data, including your breathing gas, rate of ascent or descent, maximum depth, time to surface (TTS), and the current temperature. You can press **NEXT** to view the dive compass (*Navigating with the Dive Compass, page 16*).

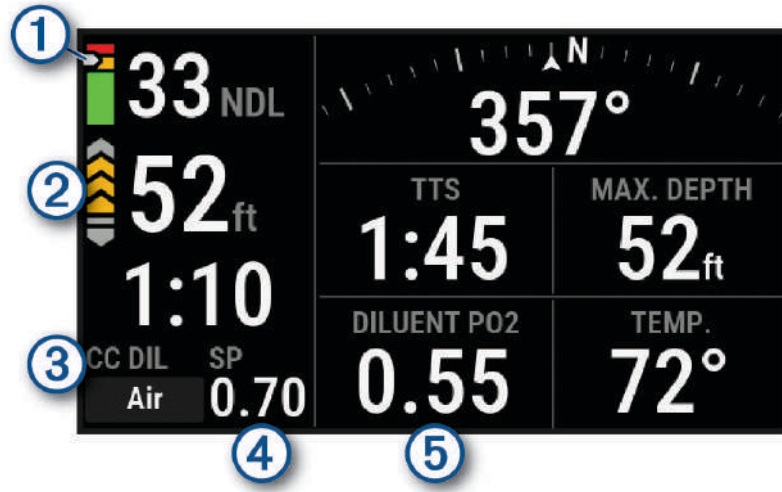

①	Your nitrogen (N ₂) and helium (He) tissue load level. <ul style="list-style-type: none"> Green: 0 to 79% tissue load. Yellow: 80 to 99% tissue load. Red: 100% or greater tissue load.
②	Your rate of ascent. <ul style="list-style-type: none"> Green: Good. Ascent is less than 7.9 m (26 ft.) per minute. Yellow: Moderately high. Ascent is between 7.9 and 10.1 m (26 and 33 ft.) per minute. Red: Too high. Ascent is greater than 10.1 m (33 ft.) per minute.
③	Indicates whether closed-circuit (CC) or open-circuit (OC) diving is active.
④	Your low partial pressure of oxygen (PO ₂) setpoint.
⑤	Your partial pressure of oxygen level of your diluent gas.

Gauge Data Screens

The primary data screen for the gauge dive mode displays data for the current dive, including your maximum depth, the lowest temperature during the dive, the time of day, and the stopwatch (*Using the Gauge Dive Stopwatch, page 16*). You can press **NEXT** to view the full screen dive compass (*Navigating with the Dive Compass, page 16*).

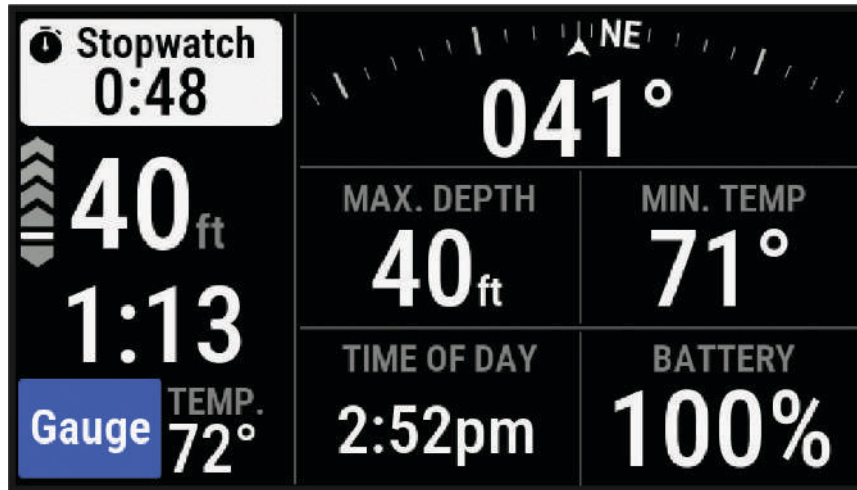

Going Diving

NOTICE

If you store the dive computer while it is still wet, it may inadvertently turn on and drain the battery.

NOTE: The dive computer turns on automatically when it detects water. If you start a dive without turning on your dive computer, the dive computer uses the most recent surface pressure to determine depth. For the most accurate depth information, turn on your dive computer manually, especially after traveling.

- 1 If necessary, select **Dive Mode**, and select a dive mode.
- 2 Select **Start Dive With**.
- 3 Review the dive setup options, and if necessary, select **View All Setup** to edit the dive settings (*Dive Setup, page 5*).
- 4 Wait with your arm out of the water until the dive computer acquires GPS signals and **GPS** turns green (optional).

The dive computer requires GPS signals to save your dive entry location.

- 5 Select **Confirm**.
- 6 Descend to start your dive.

The activity timer starts automatically when you reach a depth of 1.2 m (4 ft.).

NOTE: If you start a dive without selecting a dive mode, the dive computer uses the most recently used dive mode and settings, and your dive entry location is not saved.

- 7 Select an option:
 - Press **NEXT** to scroll through the data screens and dive compass.
TIP: You can also double tap the device to scroll through the data screens.
 - Press **ENTER** to view the in-dive menu.
- 8 When you are ready to end the dive, ascend to the surface.

9 Keep your arm out of the water so the dive computer can acquire GPS signals and save your dive exit location (optional).

10 Wait for the **DIVE END** timer to count down.

NOTE: When you ascend to 1 m (3.3 ft.), the DIVE END timer begins counting down (*Dive Setup*, page 5). You can press ENTER, and select Stop Dive to stop the dive before the timer elapses.

The dive computer saves the dive activity.

TIP: You can view your diving history in the dive log app (*Viewing the Dive Log App*, page 22).

Dry off the dive computer.

Navigating with the Dive Compass

1 During a dive, scroll to the dive compass.

NOTE: The appearance of the dive compass may vary if you view it in a data field.



The compass indicates your directional heading ①.

2 Select  > **Compass**.

3 Select an option:

- To set the heading, select **Set Heading**.

TIP: You can also set the heading by holding **NEXT** and **ENTER** (*Dive Shortcuts*, page 8).

The compass indicates deviations ③ from the set heading ②.

- To set the heading again, select **Change Heading**.
- To change the heading by 180 degrees, select **Set to Recip..**
NOTE: The compass indicates the reciprocal heading with a red mark.
- To set to a 90-degree heading left or right, select **Set to 90L** or **Set to 90R**.
- To delete the heading, select **Clear Heading**.

Using the Gauge Dive Stopwatch

1 Start a **Gauge** dive.

2 Press **ENTER**.

3 Select **Start Stopwatch**.

4 Select an option:

- To stop using the stopwatch, press **ENTER**, and select **Stop Stopwatch**.
- To restart the stopwatch, press **ENTER**, and select **Reset Stopwatch**.

Viewing Transceiver Data During a Dive

1 Press **NEXT** to view the data screen.

TIP: You can customize the dive data screens to view the transceiver and diver dashboard data on dedicated data screens (*Customizing the Data Screens, page 8*).



- | | |
|---|---|
| ① | The gas consumption estimate for your transceiver (<i>Selecting the Gas Consumption Rate Metric, page 10</i>). |
| ② | The air time remaining (ATR) estimate for your transceiver. |
| ③ | Your pinned transceivers and their tank pressure values.
NOTE: You can customize which transceivers are displayed (<i>Selecting Transceivers to View During a Dive, page 10</i>). |

2 Press **ENTER**, and select **Divers** to view the tank pressure values, approximate depths, and approximate distances of the paired Descent transceivers in the network.

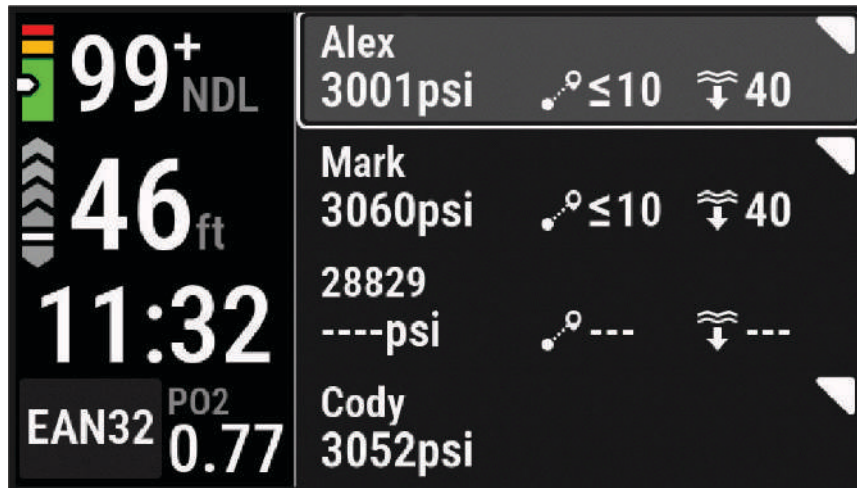

NOTE: Not all features are available for older devices (*Dive Product and Feature Compatibility, page 27*).

Switching Gases During a Dive

- 1 Start a single-gas, multi-gas, or closed-circuit rebreather (CCR) dive.
- 2 Select an option:
 - Press **ENTER**, select **Gas**, and select a backup or decompression gas.
NOTE: If necessary, you can select **Add New** and enter a new gas.
 - Dive until you reach the **MOD/Deco P02** threshold (*Setting P02 Thresholds, page 7*).
The device prompts you to switch to the gas with the highest percentage of oxygen.
NOTE: The device does not switch gases for you automatically. You must select the gas.

Switching Between CC and OC Diving for a Bailout Procedure

During a closed-circuit rebreather (CCR) dive, you can switch between closed-circuit (CC) and open-circuit (OC) diving while you perform a bailout procedure.

- 1 Start a CCR dive.
- 2 Press **ENTER**.
- 3 Select **Switch to OC**.

The gas name turns red, and the device switches the active breathing gas to your OC decompression gas.
NOTE: If you have not set up an OC decompression gas, the device switches to your diluent gas.
- 4 If necessary, press **ENTER**, and select **Gas** to manually switch to a backup gas.
- 5 Press **ENTER**, and select **Switch to CC** to switch back to CC diving.

Performing a Safety Stop

You should perform a safety stop during every dive to help reduce the risk of decompression sickness.

- 1 After a dive of at least 11 m (35 ft.), ascend to 5 m (15 ft.).
Safety stop information appears on the data screens.



① The safety stop ceiling depth.

② The safety stop timer.
When you are within 1 m (5 ft.) of the ceiling depth, the timer starts counting down.

- 2 Stay within 2 m (8 ft.) of the safety stop ceiling depth until the safety stop timer reaches zero.
NOTE: If you ascend more than 3 m (8 ft.) above the safety stop ceiling depth, the safety stop timer pauses, and the device alerts you to descend below the ceiling depth. If you descend below 11 m (35 ft.), the safety stop timer resets.
- 3 Continue ascending to the surface.

Performing a Decompression Stop

You should always perform all the required decompression stops during a dive to help reduce the risk of decompression sickness. Missing a decompression stop adds significant risk.

- 1 When you exceed the no-decompression limit (NDL) time, begin your ascent.
Decompression stop information appears on the data screens.



①	The decompression stop ceiling depth.
②	The decompression stop timer.

- 2 Stay within 0.6 m (2 ft.) of the decompression stop ceiling depth until the decompression stop timer reaches zero.
NOTE: If you ascend more than 0.6 m (2 ft.) above the decompression stop ceiling depth, the decompression stop timer pauses, and the device alerts you to descend below the ceiling depth. The depth and ceiling depth flash red until you are within the safe margin.
- 3 Continue ascending to the surface or the next decompression stop.

Viewing Your Dynamic Depth

During a gas dive, the dynamic depth data screen displays your depth profile for the dive so far, along with the projected ascent plan to the surface. The ascent plan shows required decompression steps or the safety stop (if configured), as well as upcoming gas switches and automatic set point switches.

During a gas dive, press **NEXT** to view the dynamic depth data screen.

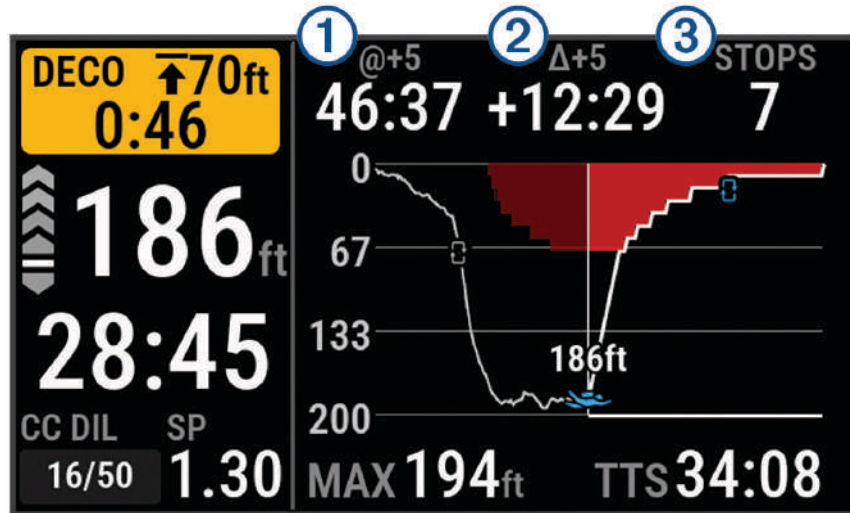

- | | |
|---|--|
| ① | Your time to surface (TTS) if you remain at the current depth for five minutes. |
| ② | The difference between your TTS, and your TTS if you remain at the current depth for five minutes. |
| ③ | Your upcoming stops. |

Viewing the Map During a Dive

1 During a dive, press **ENTER**.

2 Select **Map**.

3 Press **ENTER**.

4 Press **PREV** or **NEXT** to zoom in or out.

NOTE: You can press **ENTER** to toggle between panning up and down, panning left and right, or zooming. Location information appears at the top of the map.

Marking a Dive Event

You can use the bookmark shortcut to mark an event during your dive. For example, you can use it to mark when you see a point of interest or reach a specific point in the dive.

1 Customize a button combination for the bookmark feature ([Dive Shortcuts, page 8](#)).

2 During a dive, hold the button combination you customized to bookmark an event.

A log is created, and the bookmark appears as an event for the dive in the dive log app ([Viewing the Dive Log App, page 22](#)).

Viewing the Surface Interval App

The surface interval app shows your nitrogen (N₂) and helium (He) tissue load level, current oxygen toxicity units (OTU), and central nervous system (CNS) percentage.

NOTE: The OTU accumulated during a dive expire after 24 hours.

1 Select **SI**.

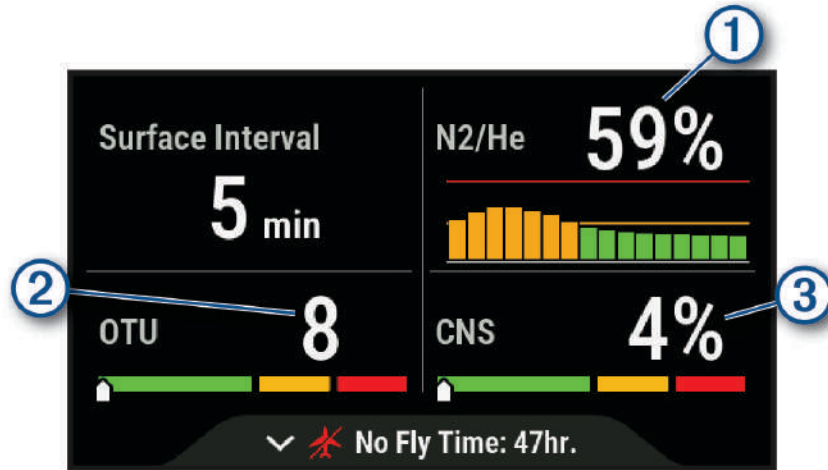

①	<ul style="list-style-type: none"> Green: 0 to 79% tissue load. Yellow: 80 to 99% tissue load. Red: 100% or greater tissue load.
②	<ul style="list-style-type: none"> Green: 0 to 249 OTU. Yellow: 250 to 299 OTU. Red: 300 or greater OTU.
③	<ul style="list-style-type: none"> Green: 0 to 79% CNS oxygen toxicity. Yellow: 80 to 99% CNS oxygen toxicity. Red: 100% or greater CNS oxygen toxicity.

2 Press **NEXT** to view your no-fly time remaining and the time of day the no-fly period ends.

Viewing the Dive Log App

The dive log app displays summaries of your recently recorded dives.

- 1 Select **Dive Log** to view your most recent dive.
- 2 If necessary, press **NEXT** to select a different dive.
- 3 Press **ENTER** to view an overview and depth graph of the activity.
- 4 Select an option:
 - To view a timeline of significant events for the dive, such as when you reached your maximum depth and when a decompression stop began, select **Events**.
 - To view a temperature graph for the dive, select **Temperature**.
 - To view the activity on a map, select **Map**.
NOTE: The dive computer shows your entry and exit locations if you waited for GPS signals before and after the dive.
 - To view additional information for the dive, select **All Stats**.

Dive Planning

You can plan for future dives using your dive computer, such as calculating your breathing gas or no-decompression limit (NDL) times.

Calculating NDL Time

You can calculate the no-decompression limit (NDL) time or maximum depth for a future dive. These calculations are not saved or applied to your next dive.

- 1 Select **Plan Dive > Compute NDL**.
- 2 Select an option:
 - To calculate NDL based on your current tissue load, select **Diving Now**.
 - To calculate NDL based on your tissue load at a future time, select **Enter Surf. Interval**, and enter your surface interval time.
- 3 Enter an oxygen percentage.
- 4 Select an option:
 - To calculate the NDL time, select **Enter Depth**, and enter the planned depth for your dive.
 - To calculate the maximum depth, select **Enter Time**, and enter your planned dive time.The NDL countdown clock, depth, and maximum operating depth (MOD) appear.
NOTE: If the planned depth exceeds the MOD of the dive computer or the breathing gas, the planned depth appears in red.
- 5 Press **ENTER**.
- 6 Select an option:
 - To exit, select **Done**.
 - To add intervals to your dive, select **Add Repeat Dive**, and follow the on-screen instructions.

Calculating Your Breathing Gas

You can calculate the PO₂ value, oxygen percentage, or maximum depth for a dive by adjusting two of the three values. The calculations are affected by the water type setting in the Dive Setup menu (*Dive Setup*, page 5).

- 1 Select **Plan Dive > Calculate Gas**.
- 2 Press **PREV** or **NEXT**, and select an option to calculate:
 - Select **PO₂**.
 - Select **O₂%**.
 - Select **Depth**.
- 3 Press **PREV** or **NEXT** to edit the first value.
- 4 Press **ENTER**, then press **PREV** or **NEXT** to edit the second value.
As you edit the values, the device calculates an adjusted value for the highlighted option.
- 5 If necessary, press **BACK** to calculate the value for a different option.

Creating a Decompression Plan

You can create open-circuit decompression plans and save them for future dives.

- 1 Select **Plan Dive > Deco Plans > Add New**.
- 2 Enter a name for the decompression plan.
- 3 Select an option:
 - To enter the maximum partial pressure of oxygen in bars, select **PO₂**.
NOTE: The dive computer uses the PO₂ value for gas switching.
 - To enter your level of conservatism for decompression calculations, select **Conservatism**.
 - To enter your gas blends, select **Gases**.
 - To enter the depth of your last decompression stop, select **Last Deco Stop**.
 - To enter the maximum dive depth, select **Bottom Depth**.
 - To enter the time at the bottom depth, select **Bottom Time**.
- 4 Select **Save**.

Using Decompression Plans

- 1 Select **Plan Dive > Deco Plans**.
- 2 Select a decompression plan.
- 3 Select an option:
 - To view the decompression plan, select **View**.
 - To use the decompression plan settings for a dive mode, select **Apply**.
 - To change the decompression plan details, select **Edit**.
 - To edit the name of the decompression plan, select **Rename**.
 - To remove the decompression plan, select **Delete > Yes**.

Altitude Diving

At higher altitudes, the atmospheric pressure is lower, and your body contains a larger amount of nitrogen than it would at the start of a dive at sea level. The dive computer accounts for altitude changes automatically using the barometric pressure sensor. The absolute pressure value used by the decompression model is not affected by the altitude or the gauge pressure displayed on the dive computer.

Dive Alerts

Alert Message	Cause	Dive Computer Action
None	You completed the decompression stop.	The decompression stop depth and time flash.
None	Your partial pressure of oxygen (PO ₂) value is above the specified warning value.	Your PO ₂ value flashes yellow.
%1 OTU accumulated.	Your oxygen toxicity units are above the safe limit. During a dive, "%1" is replaced with the number of units accumulated.	The alert appears every two minutes, up to three times.
250 OTU accumulated.	Your oxygen toxicity units (OTU) are at 250 units, and you are nearing the safe limit of 300 units.	None
5 minutes to NDL.	You have 5 minutes of no decompression limit (NDL) time remaining.	
10 minutes to NDL.	You have 10 minutes of no decompression limit (NDL) time remaining.	
Approaching deco stop.	You are within one stop interval (3 m or 9.8 ft.) of the decompression stop depth.	None
ASCEND OR SWITCH GAS PO ₂ is high.	Your PO ₂ value is above the specified critical value.	Your PO ₂ value flashes red. The alert appears every 30 seconds, up to three times, until you ascend to a safe level.
Battery is low.	Less than 20% battery power remains.	The alert appears when the dive computer is below 20% battery power.
Continuing on %1. Switch at any time.	You selected Not Now when prompted to switch to a higher-oxygen gas, or you ignored the prompt.	The gas does not change. You will be prompted again in two minutes.
CNS toxicity at 80%.	Your central nervous system (CNS) oxygen toxicity is at 80% of the safe limit.	The alert appears during a dive and on the dive pre-check screen for your next dive.
CNS toxicity at %1%.	Your CNS oxygen toxicity is too high. During a dive, "%1" is replaced with your current CNS percentage.	The alert appears every two minutes, up to three times.
Decompression cleared.	You completed all decompression stops.	None
DESCEND OR SWITCH GAS PO ₂ is low.	Your PO ₂ value is below 0.18 bar.	If you are within the first two minutes of your dive, your PO ₂ value flashes yellow. Otherwise, your PO ₂ value flashes red. The alert appears every 30 seconds, up to three times, until you descend to a safe level or switch gases.
DESCEND TO %1 You are above your deco ceiling.	You are more than 0.6 m (2 ft.) above the decompression ceiling.	The current depth and stop depth flash red. If you remain above the decompression ceiling for more than three minutes, the decompression lockout feature goes into effect.

Alert Message	Cause	Dive Computer Action
Descend to complete safety stop.	You are more than 2 m (8 ft.) above the safety stop ceiling.	The current depth and stop depth turn yellow.
Diluent PO2 is low. Flushing may be dangerous.	In a CCR dive, your diluent's PO2 value is below 0.18 bar.	Your PO2 value flashes yellow.
Dive will end in %1 seconds.	The dive computer will automatically end and save the dive. During a dive, "%1" is replaced by the number of seconds.	None
Do not dive. Failed to read depth sensor.	The dive computer has invalid or missing depth sensor data before you start a dive activity.	Do not start a dive. Call Garmin® Product Support.
EVALUATE DIVE CONDITIONS Dive computer was rebooted.	The dive computer rebooted during the dive.	The dive computer simulates the dive for the time it was rebooting. Since other alerts may not have been triggered, evaluate your current depth and dive conditions.
Hold BACK to end assistance.	Diver assistance is still active.	The alert appears every two minutes while diver assistance is still active.
NDL exceeded. Deco required.	You have exceeded your NDL time.	The dive computer begins providing decompression stop guidance.
Reminder: Torch is still on.	The dive torch has been on for 5 minutes.	The alert appears every five minutes while the torch is still on.
SAFELY END DIVE Battery critically low.	Less than 10% battery power remains.	The alert appears when the dive computer is below 10% battery power.
SAFELY END DIVE Dive computer error.	The computer encountered an issue that it could not recover from.	Use a backup dive computer or dive plan and end your dive. Residual tissue loading was cleared. If the issue continues, call Garmin Product Support.
SAFELY END DIVE Failed to read depth sensor.	The dive computer has invalid or missing depth sensor data after you have started a dive activity.	Use a backup dive computer or dive plan and end your dive. Call Garmin Product Support.
Safety stop cleared.	You completed the safety stop.	None
Safety stop started.	You ascended above 6 m (20 ft.) without other decompression guidance.	The safety stop countdown timer begins, if configured.
SLOW YOUR ASCENT Ascending too fast.	You are ascending faster than 9.1 m/min. (30 ft./min.) for more than 5 seconds.	None
Switch to %1 now?	In a multi-gas dive, a gas with a higher oxygen content is now safe to breathe. During a dive, "%1" is replaced with the name of the gas.	You can switch gases now, or wait to switch gases later in the dive. A confirmation message for your choice appears.
Switched to high setpoint.	The dive computer automatically switched to your specified CCR high setpoint.	None

Alert Message	Cause	Dive Computer Action
Switched to low setpoint.	The dive computer automatically switched to your specified CCR low setpoint.	None
This pool dive will not be saved to the dive log.	The dive computer is in pool dive mode.	The dive computer will not save the current dive to the dive log.

Transceiver Alerts

Alert Message	Cause	Device Action
None	Your paired dive computer has lost communication with the transceiver for 30 seconds.	The tank pressure value flashes yellow.
%1 is below reserve pressure.	Your tank pressure is below the reserve pressure level. "%1" is replaced with the transceiver name.	The tank pressure value turns yellow. The paired dive computer vibrates and plays a warning tone.
PRESSURE CRITICAL %1 pressure is critically low.	Your tank pressure is below the critical pressure level. "%1" is replaced with the transceiver name.	The tank pressure value flashes red. The paired dive computer vibrates and plays a warning tone.
TANK BATTERY CRITICAL %1 battery critically low.	Fewer than 20 hours of dive time remain. "%1" is replaced with the transceiver name.	The transceiver name flashes BATT. LOW when the battery is critically low. The paired dive computer vibrates and plays a warning tone.
Lost communication with %1.	Your paired dive computer has lost communication with the transceiver for 60 seconds.	The transceiver name flashes NO COMMS, dashed lines replace the tank pressure value, and the tank pressure value flashes red. The paired dive computer vibrates and plays a warning tone if connection alerts are enabled.
Transmitter %1 failed to connect.	Your paired dive computer cannot connect to the transceiver. You should update both devices to the latest software version. "%1" is replaced with the transceiver name.	The paired dive computer vibrates and plays a warning tone.

Enabling Lost Transceiver Alerts





Your paired dive computer can lose communication with the transceiver when the transceiver is out of range, when the transceiver signal is blocked by your body or that of another diver, and when the transceiver loses battery power. You can enable an alert that notifies you when your paired dive computer has lost communication with the transceiver for 60 seconds.

Select **Dive Setup > Dive Network & Air Integration > Connection Alert**.

Dive Product and Feature Compatibility

You can pair multiple Descent devices to form a dive network for you and your fellow divers. Not all features are available for older devices.

NOTE: You may need to update your devices to the latest software versions to access all features. If the software versions are incompatible, the following alert appears on the dive computer: **Transmitter %1 failed to connect..** "%1" is replaced with the transceiver name.

	Descent T1	Descent T2
Descent Mk2i	 <ul style="list-style-type: none"> • View tank pressure • View diver depth • View diver distance 	 <ul style="list-style-type: none"> • Receive messages • View tank pressure • View diver depth • View diver distance • View public tank name
Descent Mk3i and Descent X50i	 <ul style="list-style-type: none"> • View tank pressure • View diver depth • View diver distance 	 <ul style="list-style-type: none"> • Send messages • Receive messages • View tank pressure • View diver depth • View diver distance • View public tank name

: View tank pressure for yourself and connected divers.

: View diver depth for connected divers.

: View diver distance for connected divers.

: View the public transceiver names for yourself and connected divers.

: Send pre-defined messages to divers with a Descent T2 transceiver.

: Receive in-dive messages from divers with a Descent Mk3i or X50i dive computer and Descent T2 transceiver.

Dive Terminology

Air time remaining (ATR): The time you may remain at the current depth until an ascent at 9 m/min. (30 ft./min.) would result in surfacing with the reserve pressure.

Central nervous system (CNS): A measure of central nervous system oxygen toxicity caused by exposure to increased partial pressure of oxygen (PO₂) while diving.

Closed-circuit rebreather (CCR): A diving mode used for dives performed with a rebreather that recirculates exhaled gas and removes carbon dioxide.

Maximum operating depth (MOD): The greatest depth at which a breathing gas can be used before the partial pressure of oxygen (PO₂) exceeds the safe limit.

No decompression limit (NDL): A dive that does not require decompression time while ascending to the surface.

Oxygen toxicity units (OTU): A measure of pulmonary oxygen toxicity caused by exposure to increased partial pressure of oxygen (PO₂) while diving. One OTU is equivalent to breathing 100% oxygen at 1 ATM for 1 minute.

Partial pressure of oxygen (PO₂): The pressure of the oxygen in the breathing gas, based on depth and oxygen percentage.

Pressure-based surface air consumption (PSAC): The change in pressure over time, normalized to 1 ATM.

Respiratory minute volume (RMV): The change in gas volume at ambient pressure over time.

Surface interval (SI): The amount of time that has elapsed since the completion of the last dive.

Time to surface (TTS): The estimated amount of time it will take to ascend to the surface, including decompression stops.

Volumetric surface air consumption (SAC): The change in gas volume over time, normalized to 1 ATM.

Map

Your device comes preloaded with maps and can display several types of Garmin map data, including topographical contours and nearby points of interest. To purchase additional map data and view compatibility information, go to garmin.com/maps.

▲ represents your location on the map. When you are navigating to a destination, your route is marked with a line on the map.

Viewing the Map

- 1 From the home screen, scroll down to the extended app list, and select **Map**.
- 2 If necessary, wait while the dive computer locates satellites.
- 3 Select an option to pan and zoom the map:
 - To use the touchscreen, tap the map, tap and drag to position the crosshairs, and press **PREV** or **NEXT** to zoom in or out.
 - To use the buttons, press **ENTER**, select **Pan/Zoom**, and press **PREV** or **NEXT** to zoom in or out.

NOTE: You can press **ENTER** to toggle between panning up and down, panning left and right, or zooming. Location information appears at the top of the map.



Saving or Navigating to a Location on the Map

You can select any location on the map. You can save the location or start navigating to it.



- 1 From the home screen, scroll down to the extended app list, and select **Map**.
- 2 Select an option:
 - To use the touchscreen, tap the map, tap and drag to position the crosshairs, and press **PREV** or **NEXT** to zoom in or out.
 - To use the buttons, press **ENTER**, select **Pan/Zoom**, and press **PREV** or **NEXT** to zoom in or out.
NOTE: You can press **ENTER** to toggle between panning up and down, panning left and right, or zooming. Location information appears at the top of the map.
- 3 Select an option:
 - To start navigating to the location, select the location information, and select **Go**.
 - To save the location, press **ENTER**, and select **Save Location**.

Editing a Saved Location

You can view, edit, and delete saved locations.

- 1 From the home screen, scroll down to the extended app list, and select **Map** >  > **Saved Locations**.
- 2 Select a location.
- 3 Select  > **Edit Location**.
- 4 Select an option to edit.

Navigating to a Saved Location

- 1 From the home screen, scroll down to the extended app list, and select **Map** >  > **Saved Locations**.
- 2 Select a location.
- 3 Select  > **Navigate To**.

Map Settings

From the home screen, scroll down to the extended app list, select **Map** >  > **Map Setup**.

Orientation: Sets the orientation of the map. The North Up option shows north at the top of the screen. The Track Up option shows your current direction of travel at the top of the screen. Automotive Mode shows an automotive perspective with the direction of travel at the top.

Guidance Text: Sets when the guidance text is shown on the map.

Marine Setup: Customizes the marine map settings ([Marine Map Settings, page 30](#)).

Advanced Setup: Customizes the advanced map settings ([Advanced Map Settings, page 29](#)).

Advanced Map Settings

From the home screen, scroll down to the extended app list, select **Map** >  > **Map Setup** > **Advanced Setup**.

Auto Zoom: Automatically selects the zoom level for optimal use of the map. When disabled, you must zoom in or out manually.

Detail: Sets the amount of detail shown on the map. Showing more detail may cause the map to redraw more slowly.

Shaded Relief: Shows or hides relief shading for a three-dimensional view of the map topography.

Vehicle: Changes the icon that represents your position on the map.

Zoom Levels: Adjusts the zoom level at which map items will appear. The map items will not appear when the map zoom level is higher than the selected level.

Text Size: Sets the text size for map items, such as labels and waypoints.

Marine Map Settings

From the home screen, scroll down to the extended app list, and select **Map** >  > **Map Setup** > **Marine Setup**.

Marine Chart Mode: Sets the type of chart the dive computer uses. Nautical displays various map features in different colors so the marine POIs are more readable and so the map reflects the drawing scheme of paper charts. Fishing displays a simplified map presentation for optimal use while fishing.

NOTE: Some features require marine maps (*Downloading Marine Maps and Charts, page 30*).

Appearance: Sets the appearance of marine navigation aids on the map.

Downloading Marine Maps and Charts

- 1 Go to garmin.com/c/wearables-mapping to search for and purchase a marine map or chart.
- 2 Download Garmin Express.
- 3 Follow the on-screen instructions to install purchased maps and charts on your device.

Routing Settings

The available routing settings vary based on whether Direct Routing is enabled or disabled.

From the home screen, scroll down to the extended app list, and select **Map** >  > **Routing**.

Direct Routing: Enables or disables direct routing. Direct routing calculates the most direct route possible to the destination.

Activity: Sets an activity while routing. The dive computer calculates routes optimized for the type of activity you are doing.

Route Transitions: Sets how the dive computer routes from one point on the route to the next. The Distance option routes you to the next point on the route when you are within a specified distance of your current point.

Lock On Road: Locks the blue triangle, which represents your position on the map, onto the nearest road. This is most useful when driving or navigating on roads.

Advanced Setup: Customizes additional routing settings (*Advanced Routing Settings, page 30*).

Advanced Routing Settings

From the home screen, scroll down to the extended app list, and select **Map** >  > **Routing** > **Advanced Setup**.

Calculation Method: Sets the method used to calculate your route.

Off Route Recalculation: Sets recalculation preferences when navigating away from an active route.

Avoidance Setup: Sets the types of roads, terrain, and transportation methods to avoid while navigating.

Compass

Setting the Compass Heading

- 1 From the home screen, scroll down to the extended app list.
- 2 Select **Compass**.
- 3 Point the top of the dive computer toward your heading.
- 4  > **Set Heading**.

When you deviate from the heading, the compass displays the direction from the heading and degree of deviation. If you begin a dive, the compass heading is retained.

Setting the North Reference

You can set the directional reference used in calculating heading information.

- 1 From the home screen, scroll down to the extended app list.
- 2 Select **Compass** >  > **Heading Setup** > **North Reference**.
- 3 Select an option:
 - To set magnetic north as the heading without declination, select **Magnetic**.
 - To set grid north (000°) as the heading reference, select **Grid**.
 - To set the magnetic variation value manually, select **User** > **Enter Magnetic Variation**, and enter the magnetic variation.
 - To set geographic north as the heading reference, select **True**.

Calibrating the Compass

NOTICE

Calibrate the electronic compass outdoors. To improve heading accuracy, do not stand near objects that influence magnetic fields, such as vehicles, buildings, and overhead power lines.

If you experience irregular compass behavior, for example, after moving long distances or after extreme temperature changes, you can manually calibrate the compass.

- 1 From the home screen, scroll down to the extended app list.
- 2 Select **Compass** >  > **Calibrate Compass**.
- 3 Follow the on-screen instructions.

Connectivity

Connectivity features are available for your dive computer when you pair with your compatible phone ([Pairing Your Phone, page 31](#)). Additional features are available when you connect your dive computer to a Wi-Fi network ([Connecting to a Wi-Fi Network, page 32](#)).

Phone Connectivity Features

Phone connectivity features are available for your Descent dive computer when you pair it using the Garmin Dive app ([Pairing Your Phone, page 31](#)).

Data uploads to the Garmin Dive app: Automatically syncs your data with the Garmin Dive app and your Garmin Connect™ account.

Software updates: Downloads and installs the latest software.

Notifications: Alerts you to notifications from your phone, including calls, texts, and apps, based on your phone notification settings.

Pairing Your Phone

To use the connected features on your dive computer, you must pair it directly through the Garmin Dive app, instead of from the Bluetooth settings on your phone.

- 1 Select an option:
 - During the initial setup on your dive computer, scan the QR code with your phone.
 - If you previously skipped the pairing process, scroll down from the home screen to view the extended app list, select **Settings** > **Connectivity** > **Phone** > **Pair Phone**, and scan the QR code with your phone.
- 2 Follow the on-screen instructions to complete the pairing and setup process.

Garmin Dive App

The Garmin Dive app allows you to upload your dive logs from your compatible Garmin device. You can add more detailed information about your dives, including environmental conditions, photos, notes, and dive buddies. You can use the map to browse for new dive locations, and view the location details and photos shared by other users.

The Garmin Dive app syncs your data with your Garmin Connect account. You can download the Garmin Dive app from the app store on your phone (garmin.com/diveapp).

Wi-Fi Connectivity Features

Activity uploads to your Garmin Connect account: Automatically sends your activity to your Garmin Connect account as soon as you finish recording the activity.

Software updates: Downloads and installs the latest software.

Connecting to a Wi-Fi Network

- 1 From the home screen, scroll down to the extended app list.
- 2 Select **Settings > Connectivity > Wi-Fi > My Networks > Add Network**.
The dive computer displays a list of nearby Wi-Fi networks.
- 3 Select a network.
- 4 If necessary, enter the password for the network.

The dive computer connects to the network, and the network is added to the list of saved networks. The dive computer reconnects to this network automatically when it is within range.

Wireless Sensors

Your dive computer can be paired and used with compatible wireless sensors using ANT+® or Bluetooth technology.

For information about specific Garmin sensor compatibility, purchasing, or to view the owner's manual, go to buy.garmin.com for that sensor.

inReach® Remote

The inReach remote function allows you to control your inReach device using your Descent device. Go to buy.garmin.com to purchase a compatible inReach device.

Using the inReach Remote

- 1 Turn on the inReach satellite communicator.
- 2 From the home screen on your dive computer, scroll down to the extended app list.
- 3 Select **inReach Remote > Yes**.
The dive computer searches for your inReach satellite communicator.
- 4 Select your inReach satellite communicator.
- 5 Once your inReach satellite communicator is paired, select an option:
 - To send an SOS message, select **SOS > Initiate SOS**.
NOTE: You should only use the SOS function in a real emergency situation.
 - To send a text message, select **Messages > Type Message**, select the message contacts, and enter the message text or select a quick text option.
 - To send a preset message, select **Messages > Send Preset**, and select a message from the list.
 - To view the timer and distance traveled during an activity, select **Tracking**.

Settings

From the home screen, scroll down to the extended app list, and select **Settings**.

Dive Setup: Customizes the dive settings (*Dive Setup, page 5*).

Sound and Vibe: Sets the dive computer sounds, such as button tones, alerts, and vibrations.

Display & Brightness: Adjusts the screen settings (*Display and Brightness Settings, page 33*).

Connectivity: Pairs your dive computer to a phone, wireless network, or wireless sensor (*Connectivity, page 31*).

System: Sets the system settings, such as device language, satellite preferences, and time format (*System Settings, page 33*).

Display and Brightness Settings

From the home screen, scroll down to the extended app list, and select **Settings > Display & Brightness**.

Brightness: Sets the brightness level of the screen.

Auto Backlight: Automatically adjusts the backlight brightness based on the ambient light.

Surface Screen Timeout: Sets the length of time before the screen turns off when not in dive mode.

NOTE: The dive computer turns off entirely when there are no button presses for 30 minutes outside of a dive.

Touch: Enables the touchscreen.

System Settings

From the home screen, scroll down to the extended app list, and select **Settings > System**.

Text Language: Sets the language displayed on the dive computer (*My device is in the wrong language, page 43*).

Shortcuts: Assigns button shortcuts for use on the surface.

Compass: Calibrates the compass and sets the north reference of the compass (*Compass, page 30*).

Satellites: Sets the default satellite system (*Satellite Settings, page 33*).

Time: Sets the time format and time zone.

Advanced: Sets the unit and position format preferences, and sets the dive computer to use MTP (media transfer protocol) or Garmin mode when connected to a computer.

Reset: Resets tissues, deletes data, and resets settings (*Resetting All Default Settings, page 34*).

Check for Updates: Downloads and installs software updates when your dive computer is paired to your phone or connected to a Wi-Fi network.

About: Displays device, software, license, and regulatory information.

Satellite Settings

You can change the satellite systems used by the dive computer. For more information about satellite systems, go to garmin.com/aboutGPS.

From the home screen, scroll down to the extended app list, and select **Settings > System > Satellites**.

Off: Disables satellite systems.

GPS Only: Enables the GPS satellite system.

All Systems: Enables multiple satellite systems. Using multiple satellite systems together offers increased performance in challenging environments and faster position acquisition than using GPS only. However, using multiple systems can reduce battery life more quickly than using GPS only.

Resetting All Default Settings

Before you reset all default settings, you should sync the dive computer with the Garmin Dive app to upload your dive data.

You can reset all of the device settings to the factory default values.

- 1 From the home screen, scroll down to the extended app list.
- 2 Select **Settings > System > Reset**.
- 3 Select an option:
 - To reset all of the device settings to the factory default values and save all user-entered information and activity history, select **Reset Default Settings**.
 - To delete your tissue load data for scuba diving, select **Reset Tissues**.

NOTE: You should reset your tissue load only if you do not plan to use the dive computer again in the future. This can be useful for dive shops that provide dive computers for rent.

 - To reset all of the device settings to the factory default values and delete all user-entered information and activity history, select **Delete Data and Reset Settings**.

Device Information

Charging the Device

⚠ WARNING

This device contains a lithium-ion battery. See the *Important Safety and Product Information* guide in the product box for product warnings and other important information.

NOTICE

To prevent corrosion, thoroughly clean and dry the contacts and the surrounding area before charging or connecting to a computer. Refer to the cleaning instructions (*Device Care*, page 39).

- 1 Pinch the sides of the charging clip.
- 2 Align the clip with the contacts on the back of the device, and release the clip.

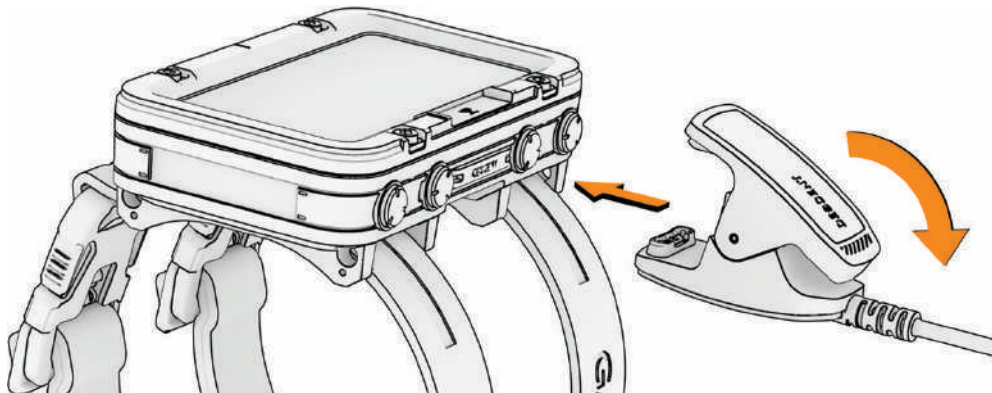

- 3 Plug the USB cable into a USB charging port.

Wearing the Device

The dive computer can be worn at any location on your arm.

- 1 Fasten both buckles on the bands around your arm.

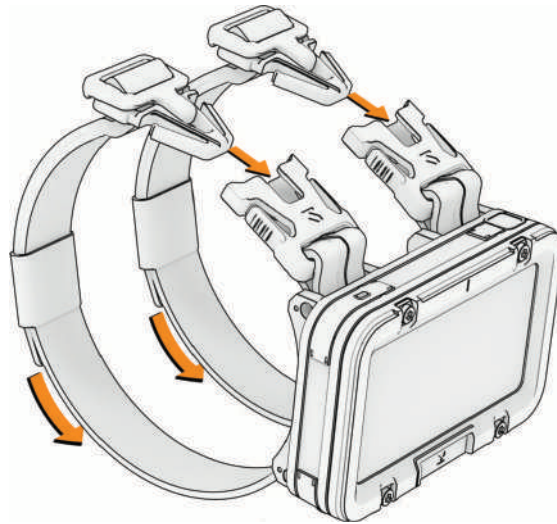

- 2 If necessary, pull the ends of the bands to tighten them.

Changing the Bands

You can replace the bands with new Descent X50i bands.

- 1 Use the included pin removal tool to push in the pin on one of the bands, and remove the pin.

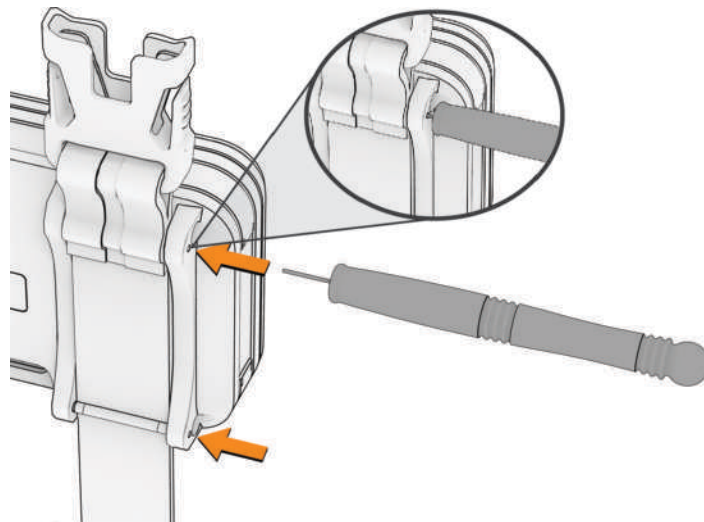

- 2 Repeat step 1 on the second pin.
- 3 Remove the band.

4 Insert a pin through the double-stitched loop on the new band.

NOTICE

Do not insert the pin through the product tag. This may cause the tag to tear.

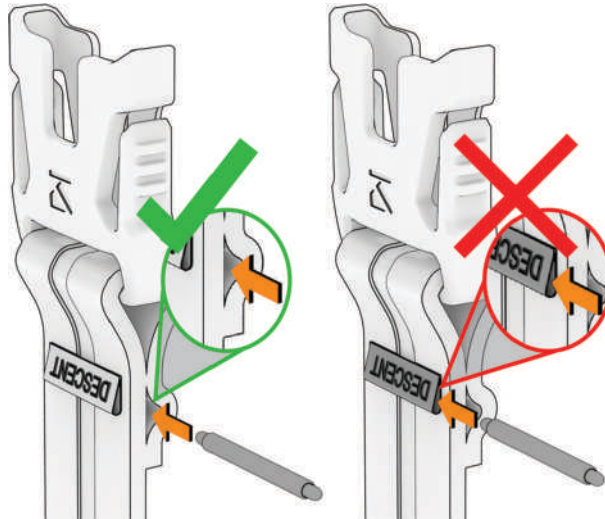

- 5 Install one end of the pin into the corresponding hole on the dive computer.
- 6 Push in the exposed pin, and press it into place.
- 7 Install the second pin above the band.

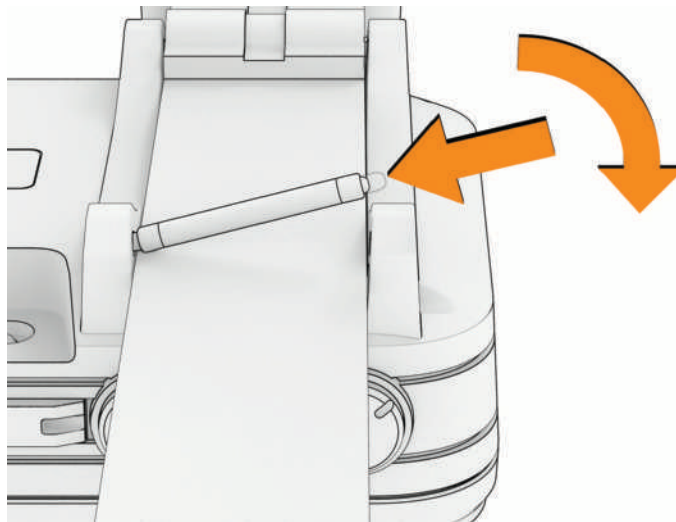

8 Repeat the steps to change the other band.

Installing Bungee Cords

⚠ WARNING

You can fuse the ends of the bungee cord by melting it or by using heat shrink in a well-ventilated area. Do not use open flame to fuse the ends of the cord, and do not fuse the ends of the cord near clothing or bare skin, as doing so could result in property damage or serious personal injury.

⚠ CAUTION

The user should never cut the bungee cord while it is on the user's arm, as this could result in property damage or personal injury.

NOTICE

It is the user's responsibility to ensure the bungee cord straps are cut to the appropriate length and that an appropriate knot is tied to ensure the dive computer remains attached to the arm. Garmin is not responsible for any loss or damage to a dive computer resulting from the dive computer coming off the arm.

The dive computer is compatible with 3 mm (1/8 in.) bungee cords (not included).

- 1 Remove the existing bands from the dive computer (*Changing the Bands, page 35*).
- 2 Cut a piece of bungee cord that is long enough to wrap around your wrist, plus approximately 5 cm (2 in.) to allow for tying the knots.
- 3 Thread the cord through the outside of one of the large holes in the dive computer's lug.



- 4 Tie an overhand knot, and tighten the knot by applying tension to both ends. The finished knot should prevent the cord from slipping through the hole.
TIP: If preferred, you can tie a figure eight knot instead.
- 5 Route the remaining end of the band through the large hole at the opposite end of the lug.
- 6 Hold the cord to your wrist, examine the fit, and determine where to tie the second knot.

- 7 Repeat steps 2 through 6 for the second bungee cord.
- 8 Cut off the excess cord, and leave at least 6 mm (0.25 in.) at the end of each knot.

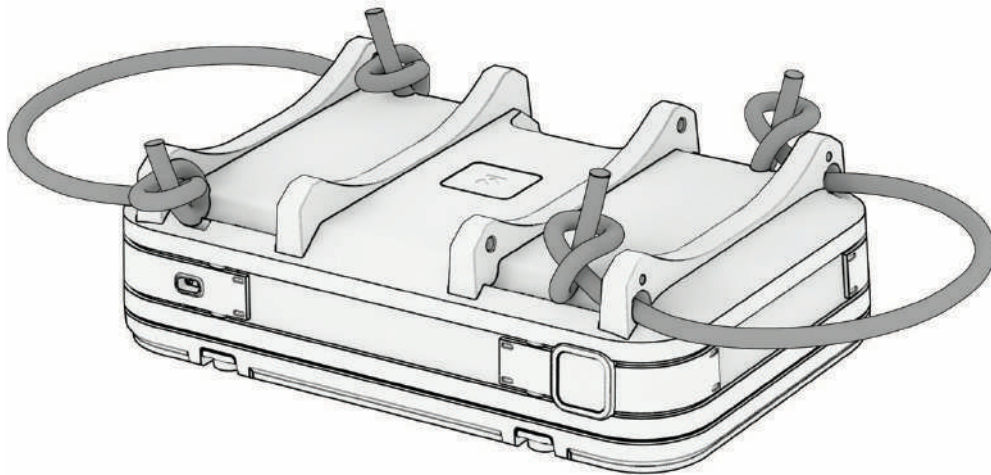

Specifications

Battery type	Rechargeable, built-in lithium-ion battery
Water rating	20 ATM ¹ Dive (EN 13319) ²
Decompression model	Bühlmann ZHL-16C
Operating and storage temperature range	From -20° to 45°C (from -4° to 113°F)
Underwater operating temperature range	From 0° to 40°C (from 32° to 104°F)
USB charging temperature range	From 0° to 45°C (from 32° to 113°F)
European Union (EU) wireless frequencies (power)	2.4 GHz @ 15 dBm maximum
EU SAR values	0.006 W/kg limb, 0.006 W/kg torso
Depth sensor	Accurate from 0 m to 200 m (0 ft. to 656 ft.) complying with EN 13319 Resolution (m): 0.1 m until 99.9 m, 1 m at 100 m Resolution (ft.): 1 ft.
Inspection interval	Inspect parts before each use for damage. Replace parts as needed. ³

¹ The device withstands pressure equivalent to a depth of 200 m. For more information, go to www.garmin.com/waterrating.

² Designed to comply with CSN EN 13319.

³ Aside from normal wear and tear, performance is not affected by aging.

Battery Information

The actual battery life depends on how much you use GPS, optional wireless sensors, the torch (flashlight), and the backlight.

Mode	Battery Life
Dive mode with display brightness set to High	Up to 13 hours
Dive mode with display brightness set to Medium	Up to 16 hours
Dive mode with display brightness set to Night Dive	Up to 20 hours

Device Care

NOTICE

Do not use a sharp object to clean the device.

Avoid chemical cleaners, solvents, and insect repellents that can damage plastic components and finishes.

Thoroughly rinse the device with fresh water after exposure to chlorine, salt water, sunscreen, cosmetics, alcohol, or other harsh chemicals. Prolonged exposure to these substances can damage the case.

Do not wash the device under high pressure, because jets of water or air may cause damage to the depth sensor or barometer.

Avoid extreme shock and harsh treatment, because it can degrade the life of the product.

Do not store the device where prolonged exposure to extreme temperatures can occur, because it can cause permanent damage.

Discontinue use if the device is damaged or if it is stored at a temperature outside the specified storage temperature range.

Cleaning the Device

⚠ CAUTION

Some users may experience skin irritation after prolonged use of the dive computer, especially if the user has sensitive skin or allergies. If you notice any skin irritation, remove the dive computer and give your skin time to heal. To help prevent skin irritation, ensure the dive computer is clean and dry, and do not overtighten the dive computer on your arm.

NOTICE

Even small amounts of sweat or moisture can cause corrosion of the electrical contacts when connected to a charger. Corrosion can prevent charging and data transfer.

If you store the dive computer while it is still wet, it may inadvertently turn on and drain the battery.

TIP: For more information, go to garmin.com/fitandcare.

- 1 Rinse with water, or use a damp lint-free cloth.
- 2 Allow the dive computer to dry completely.

Data Fields

NOTE: Not all data fields are available for all activity types. Some data fields require a paired transceiver to display data. Some data fields appear in more than one category on the dive computer.

Name	Description
Air Time Remaining	The amount of time remaining on the current air tank.
Approximate Depth	The current depth of the paired transceiver.
Approximate Distance	Your current distance from the paired transceiver.
Ascent Rate	The current rate of ascent toward the surface.
Average Depth	The average depth descended during a dive.
Avg Temperature	The average temperature during the dive.
Bailout TTS	The amount of time required to reach the surface if you switch to an open-circuit bailout gas.
Battery Percentage	The percentage of the battery power remaining.
Battery, Time, & Temp.	The percentage of the battery power remaining, the time of day based on your current location and time settings (format, time zone, daylight saving time), and the temperature of the air.
Compass	A visual representation of the direction in which the device is pointing.
Compass Heading	The direction you are moving based on the compass.
Conservatism	The level of conservatism for decompression calculations.
CNS	Your current central nervous system (CNS) oxygen toxicity percentage.
Current Gas PO ₂	The partial pressure of oxygen (PO ₂) of the current gas during a closed-circuit rebreather (CCR) dive.
Diluent PO ₂	The partial pressure of oxygen (PO ₂) of the diluent gas during a closed-circuit rebreather (CCR) dive, even if you are bailed out to an open-circuit gas.
FiO ₂	The percentage composition of oxygen in the current gas.
Gas Consumption Rate	The gas consumption rate for your transceiver.
Gas Density	The density of the selected gas at the current depth and temperature.
GF99	The current gradient factor.
Maximum Depth	The maximum depth descended during a dive.
Max Temperature	The maximum temperature during the activity.
Min Temperature	The minimum temperature during the activity.
N ₂ /He%	The nitrogen/helium tissue loading percentage.
None	This is a blank data field.
OTU	Your current oxygen toxicity units (OTU).
Pinned Tanks	The paired transceivers that appear on the transceiver data screen.
Raw Ceiling	The unrounded depth the diver should not ascend past.
Stopwatch	The stopwatch time for the current dive.
Sunrise	The time of sunrise based on your GPS position.

Name	Description
Sunset	The time of sunset based on your GPS position.
Surface Gradient Factor	The expected gradient factor if the diver were to instantaneously surface.
Tank Combo	The current tank pressure and depth of the paired transceiver, and your distance from it.
Tank Pressure	The current tank pressure of the paired transceiver.
Temperature	The temperature of the water. Your body temperature affects the temperature sensor.
Time of Day	The time of day based on your current location and time settings (format, time zone, daylight saving time).
Time of Day (Seconds)	The time of day including seconds.
Time to Surface	The amount of time required to safely ascend to the surface.
Tissue Graph (GF)	A bar chart displaying simulated values for nitrogen and helium in the body, with the y-axis of the field adjusted to your conservatism.
Tissue Graph (Raw)	A bar chart displaying simulated values for nitrogen and helium in the body.
TTS @ +5 min.	The amount of time required to safely ascend to the surface if you remain at your current depth for five minutes.
TTS Δ +5 min.	The difference between the amount of time required to safely ascend to the surface, and the amount of time required to safely ascend to the surface if you remain at your current depth for five minutes.

Troubleshooting

Product Updates

On your computer, install Garmin Express (www.garmin.com/express).

This provides easy access to these services for Garmin devices:

- Software updates
- Map updates
- Product registration

Getting More Information

You can find more information about this product on the Garmin website.

- Go to support.garmin.com for additional manuals, articles, and software updates.
- Go to buy.garmin.com, or contact your Garmin dealer for information about optional accessories and replacement parts.

My device is in the wrong language

You can change the device language selection if you have accidentally selected the wrong language on the dive computer.

- 1 From the home screen, scroll down to the extended app list.
- 2 Select .
- 3 Scroll down to the last item in the list, and press **ENTER**.
- 4 Press **ENTER**.
- 5 Select your language.

Is my smartphone compatible with my device?

The Descent X50i device is compatible with smartphones using Bluetooth technology.

Go to garmin.com/ble for compatibility information.

My phone will not connect to the device

If your phone will not connect to the device, you can try these tips.

- Turn off your phone and your device, and turn them back on again.
- Enable Bluetooth technology on your phone.
- Update the Garmin Dive app to the latest version.
- Remove your device from the Garmin Dive app and the Bluetooth settings on your phone to retry the pairing process.
- If you bought a new phone, remove your device from the Garmin Dive app on the phone you intend to stop using.
- Bring your phone within 10 m (33 ft.) of the device.
- On your phone, open the Garmin Dive app, select **•••**, and select **Garmin Devices > Add Device** to enter pairing mode.

Diving

Resetting Your Tissue Load

You can reset your current tissue load saved on the dive computer. You should reset your tissue load only if you do not plan to use the dive computer again in the near future. This can be useful for dive shops that provide dive computers for rent.

- 1 From the home screen, scroll down to the extended app list.
- 2 Select **Settings > System > Reset > Reset Tissues**.

Resetting the Surface Pressure

The device automatically determines the surface pressure using the barometric altimeter. Large pressure changes, such as during a flight, can cause the dive computer to automatically start a dive activity. If the dive computer starts a dive activity incorrectly, you can reset the surface pressure by connecting the dive computer to a computer. If you do not have access to a computer, you can reset the surface pressure manually.

- 1 Hold **PWR** until the dive computer turns off.
- 2 Hold **PWR** to turn on the dive computer.
- 3 When the product logo appears, hold **NEXT** until you are prompted to reset the surface pressure.

Acquiring Satellite Signals

The device may need a clear view of the sky to acquire satellite signals. The time and date are set automatically based on the GPS position.

TIP: For more information about GPS, go to garmin.com/aboutGPS.

- 1 Go outdoors to an open area.
The front of the device should be oriented toward the sky.
- 2 Wait while the device locates satellites.
It may take 30–60 seconds to locate satellite signals.

Improving GPS Satellite Reception

- Frequently sync the device to your Garmin account:
 - Connect your device to a computer using the USB cable and the Garmin Express application.
 - Connect your device to your Garmin account using a Wi-Fi wireless network.

While connected to your Garmin account, the device downloads several days of satellite data, allowing it to quickly locate satellite signals.

- Take your device outside to an open area away from tall buildings and trees.
- Remain stationary for a few minutes.



**Магазин спортивных часов
и пульсометров**

**8 (800) 333-57-82
<https://magazin-sportlife.ru>**